

Please check the examination details below before entering your candidate information

Candidate surname

Other names

Pearson Edexcel
International
Advanced Level

Centre Number

--	--	--	--	--

Candidate Number

--	--	--	--	--

Monday 18 May 2020

Afternoon (Time: 1 hour 45 minutes)

Paper Reference **WPH14/01**

Physics

International Advanced Level

Unit 4: Further Mechanics, Fields and Particles

You must have:

Scientific calculator, Ruler

Total Marks

Instructions

- Use **black** ink or **black** ball-point pen.
- **Fill in the boxes** at the top of this page with your name, centre number and candidate number.
- Answer **all** questions.
- Answer the questions in the spaces provided – *there may be more space than you need.*
- **Show all your working in calculations and include units where appropriate.**

Information

- The total mark for this paper is 90.
- The marks for **each** question are shown in brackets – *use this as a guide as to how much time to spend on each question.*
- In questions marked with an **asterisk** (*), marks will be awarded for your ability to structure your answer logically showing how the points that you make are related or follow on from each other where appropriate.
- The list of data, formulae and relationships is printed at the end of this booklet.

Advice

- Read each question carefully before you start to answer it.
- Try to answer every question.
- Check your answers if you have time at the end.

Turn over ►

P65749RA

©2020 Pearson Education Ltd.

1/1/1/1/1/1/1/1/1



P 6 5 7 4 9 R A 0 1 3 2



Pearson

SECTION A

Answer ALL questions.

For questions 1–10 select one answer from A to D and put a cross in the box .
If you change your mind, put a line through the box and then
mark your new answer with a cross .

- 1 Two equal positive charges are placed at Y and Z.

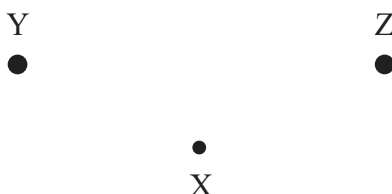

Point X is equidistant from Y and Z.

Which of the following shows the direction of the electric field at point X?

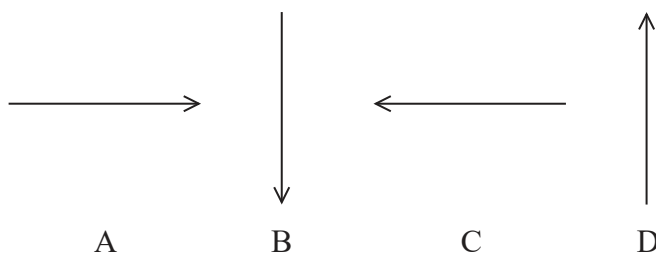

- A
 B
 C
 D

(Total for Question 1 = 1 mark)

- 2 A student writes the following equation for the decay of a neutron.

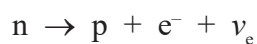

Which of the following conservation laws is violated by the equation he has written?

- A baryon number
 B charge
 C energy
 D lepton number

(Total for Question 2 = 1 mark)



- 3 A potential difference (p.d.) V is connected across a capacitor of capacitance C .
The charge stored on the capacitor is Q .

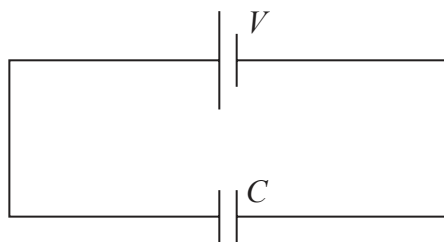

The capacitor is replaced with two capacitors, each of capacitance $2C$, in parallel.

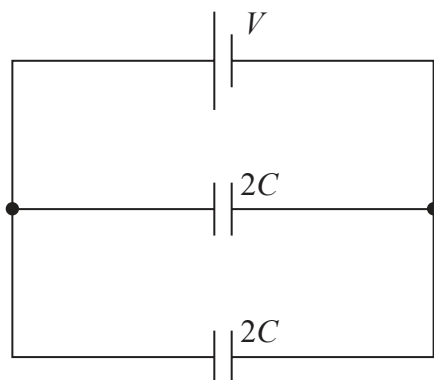

What is the total charge stored?

- A $\frac{Q}{4}$
- B Q
- C $2Q$
- D $4Q$

(Total for Question 3 = 1 mark)

- 4 The SI unit of capacitance is the farad.

Which of the following gives the base units of the farad?

- A CV^{-1}
- B C^2J^{-1}
- C $kg^{-1}m^{-2}A^2s^4$
- D $kg^{-1}m^{-2}s^{-2}C^{-2}$

(Total for Question 4 = 1 mark)



- 5 A gas molecule of mass m travelling at speed v strikes the side of a gas cylinder at an angle θ . The collision takes time t .



What is the average force acting on the side of the gas cylinder?

- A $\frac{mv}{t}$
- B $\frac{2mv}{t}$
- C $\frac{mv \sin \theta}{t}$
- D $\frac{2mv \sin \theta}{t}$

(Total for Question 5 = 1 mark)

DO NOT WRITE IN THIS AREA

DO NOT WRITE IN THIS AREA

DO NOT WRITE IN THIS AREA



- 6 An oil drop with charge q and mass m remains stationary between two metal plates with a potential difference V across them. The plates are separated by distance d .

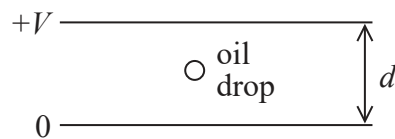

What is the charge on the oil drop?

- A $\frac{md}{V}$
- B $\frac{mV}{d}$
- C $\frac{mgd}{V}$
- D $\frac{mgV}{d}$

(Total for Question 6 = 1 mark)

- 7 A proton enters a magnetic field at an angle as shown.

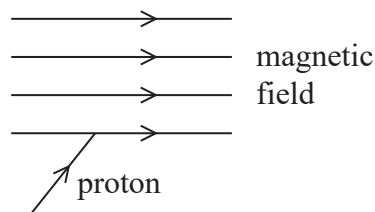

Which of the following gives the direction of the force on the proton as it enters the magnetic field?

- A in the plane of the page at 90° to the direction of the magnetic field
- B in the plane of the page at 90° to the proton velocity
- C into the page
- D out of the page

(Total for Question 7 = 1 mark)



- 8 When a point object with charge $+Q$ is placed a distance d away from another point object with charge $+2Q$ the force between them is F .

The charges are increased to $+2Q$ and $+4Q$ and the distance is increased to $2d$.

Which of the following gives the new force?

- A $\frac{F}{4}$
- B $\frac{F}{2}$
- C F
- D $2F$

(Total for Question 8 = 1 mark)

- 9 A turntable for playing vinyl records rotates at 33 revolutions per minute.

What is the angular velocity in radian s^{-1} ?

- A $33 \times 60 \times 2\pi$
- B $\frac{33}{(60 \ 2\pi)}$
- C $\left(\frac{33}{60}\right) \times 2\pi$
- D $33 \times 2\pi$

(Total for Question 9 = 1 mark)



- 10 A magnet is dropped vertically through a coil, producing a current in the coil which creates a magnetic field around it.

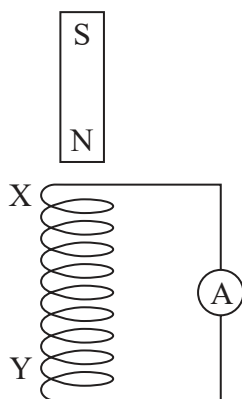

Which line of the table correctly shows the pole at X when the magnet enters the coil, and the pole at Y when the magnet leaves the coil?

	pole of field due to coil at X	pole of field due to coil at Y
<input type="checkbox"/> A	north	north
<input type="checkbox"/> B	north	south
<input type="checkbox"/> C	south	north
<input type="checkbox"/> D	south	south

(Total for Question 10 = 1 mark)

TOTAL FOR SECTION A = 10 MARKS



SECTION B

Answer ALL questions.

11 The photograph shows a model electric motor.

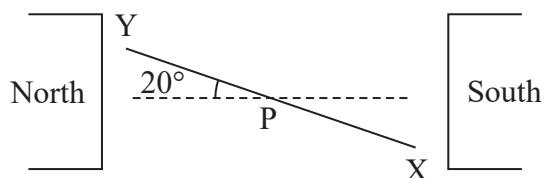

A coil of wire is mounted between two magnets. When there is a current in the coil, it rotates.

The diagram shows the position of the coil, viewed from one end, when it is at an angle of 20° to the horizontal. The current is into the page at X and out of the page at Y.

There are 10 turns on the coil and the current in the coil is 6.9 A.

Determine the resultant moment about P of the magnetic forces acting on the coil.

length of coil = 5.0 cm

width of coil = 3.5 cm

current = 6.9 A

number of turns = 10

magnetic flux density = 0.07 T

(4)

Moment about P =

(Total for Question 11 = 4 marks)



12 Positron emission tomography (PET) is a medical imaging technique used to create three-dimensional images of the body.

In PET, a low energy positron collides with an electron to produce a pair of gamma photons travelling in opposite directions. The gamma photons are detected and used to form the image.

(a) Name the process involved in producing the gamma photons. (1)

(b) Calculate the maximum wavelength of the gamma photons produced. (4)

Wavelength =

(Total for Question 12 = 5 marks)



13 In 1964 George Zweig proposed a model for matter.

Zweig suggested that mesons and baryons are made from a set of fundamental particles he called aces. In this model each ace carried baryon number $1/3$ and was fractionally charged. Baryons were a combination of three aces and mesons were a combination of two aces. Zweig said that the number of aces should match the number of leptons, so there would be four types of ace.

Compare this model with the current standard model.

(4)

.....

.....

.....

.....

.....

.....

.....

.....

.....

.....

(Total for Question 13 = 4 marks)



14 In the alpha particle scattering experiment a beam of alpha particles is directed at a thin metal foil.

- (a) In 1911 Rutherford concluded that the atom has a central charge contained in a very small volume.

Explain how the results of the experiment led to this conclusion.

(2)

.....

.....

.....

.....

- (b) Rutherford wrote, "The main deductions from the theory are independent of whether the central charge is positive or negative."

Discuss why the observations did not allow Rutherford to conclude whether the central charge is positive or negative.

You may wish to use diagrams to illustrate your response.

(4)

.....

.....

.....

.....

.....

.....

.....

.....

.....



DO NOT WRITE IN THIS AREA

DO NOT WRITE IN THIS AREA

DO NOT WRITE IN THIS AREA

(c) We now know that the nucleus is positively charged.

An alpha particle with kinetic energy of 6.29 MeV approaches a platinum nucleus and is repelled. The proton number of platinum is 78.

Calculate the minimum distance of the alpha particle from the platinum nucleus.

Assume that the alpha particle and the nucleus are point charges.

(3)

.....

.....

.....

.....

.....

.....

.....

Distance =

(Total for Question 14 = 9 marks)



15 A student carried out an investigation to compare the energy stored in a mechanical mouse trap with the energy stored in an electronic mouse trap.

- (a) The photographs show the mechanical version trap before and after it is set to trap a mouse.

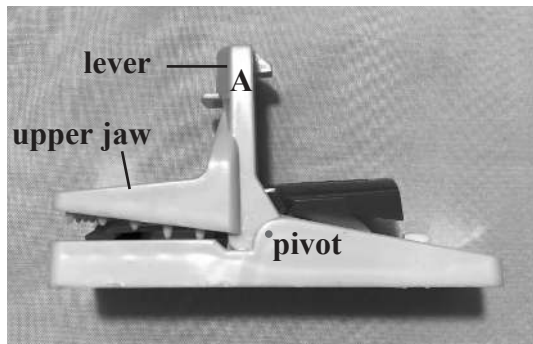

Before being set

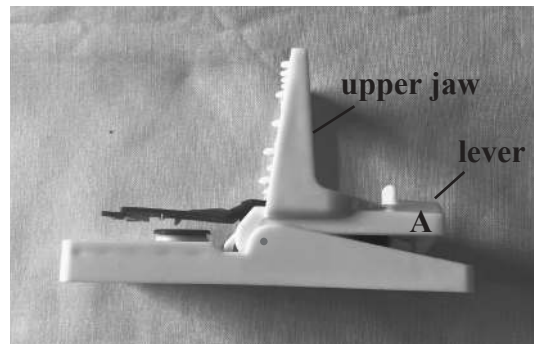

After being set

The trap was set by applying a force on the lever at point A. The lever rotated through an angle of 90° , stretching a spring. The force was applied at right angles to the lever throughout the process.

The initial force applied was 2.6 N and the force increased steadily to a final value of 9.6 N when the trap was set.

Show that the work done setting the trap was about 0.5 J .

length of lever = 4.9 cm

(2)



- (b) The electronic mouse trap works by applying a large potential difference (p.d.) across two metal plates. The diagram shows part of the circuit for the electronic mouse trap.

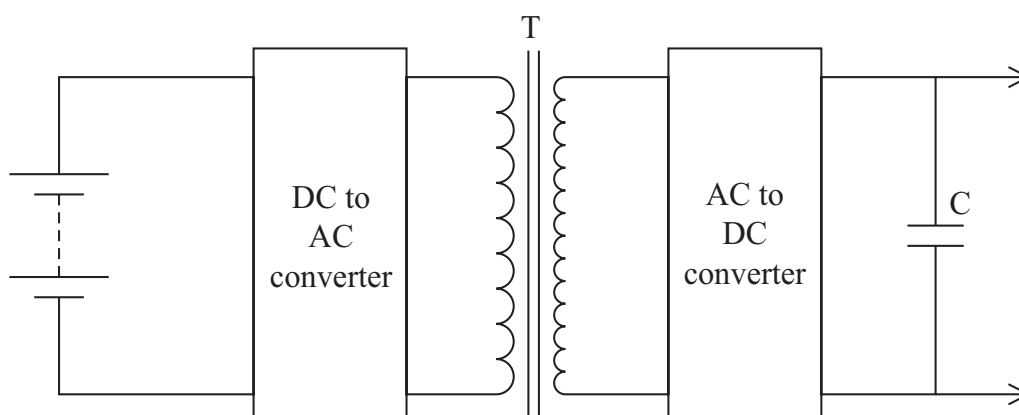

- *(i) The transformer T consists of two coils wound around a single iron core. An alternating p.d. is applied to the input coil and the output coil is connected, through a diode, to a capacitor.

Explain how applying a p.d. across the input coil causes the capacitor to charge.

(6)

.....

.....

.....

.....

.....

.....

.....

.....

.....



(ii) The graph shows how the magnetic flux density B in the iron core varies with time.

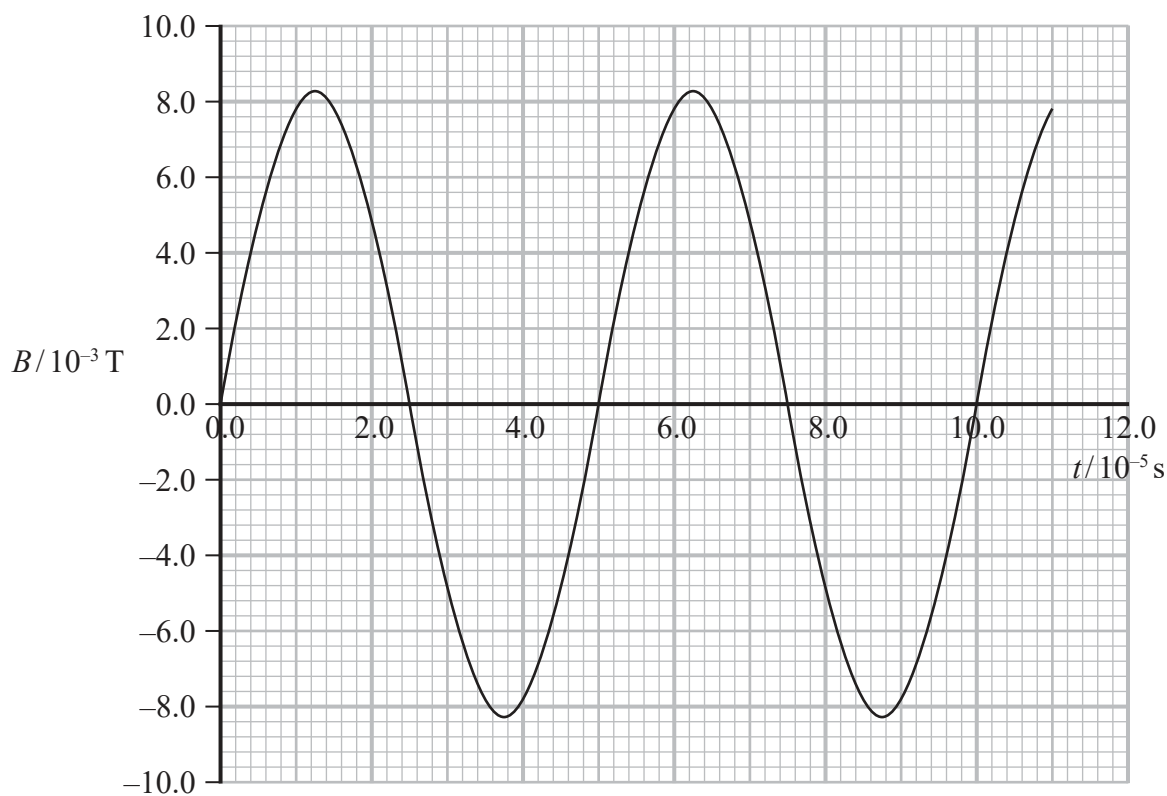

Show that the maximum p.d. across the output coil is about 600 V.

number of turns on coil = 1700

cross-sectional area of coil = $3.5 \times 10^{-4} \text{ m}^2$

(3)

.....

.....

.....

.....

.....

.....

.....



- (c) The student tested the capacitor by charging it until the p.d. across the capacitor was 600 V and recording the p.d. as it was discharged through a resistor of resistance $3000\ \Omega$.

The following graph was obtained.

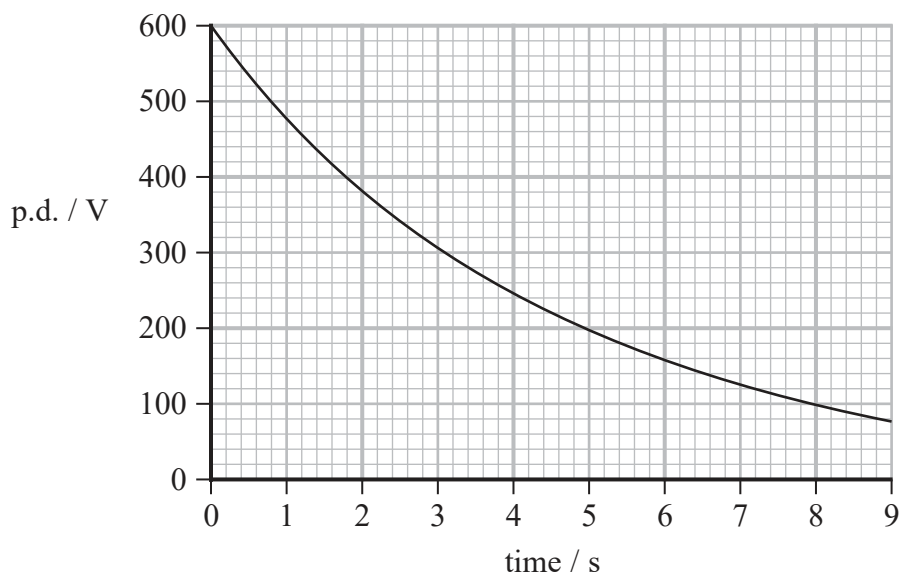

Determine whether the mechanical or the electric mouse trap stores the most energy.

(5)

.....

.....

.....

.....

.....

.....

.....

(Total for Question 15 = 16 marks)



- 16 (a) An object travels with speed v around a circular path of radius r . The diagram shows two positions, A and B on the path.

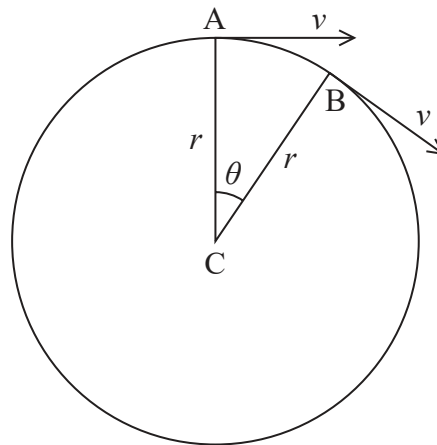

The acceleration of the object is a .

Derive the expression $a = \frac{v^2}{R}$

You should include a vector diagram.

(4)

.....

.....

.....

.....

.....

.....

.....

.....

.....

.....

.....

.....

.....

.....

.....

.....

.....

.....

.....

.....

.....

.....

.....



- (b) The photograph shows a toy with small aeroplanes suspended from a canopy by wires.



As the platform rotates, the aeroplanes rise and follow a circular path.



At a particular speed, the aeroplanes follow a circular path of diameter 10.8 cm and the wires make an angle of 19° to the vertical.

- (i) Complete a free body force diagram for one of the aeroplanes at this speed.

(1)



- (ii) Show that, at this speed, the time for an aeroplane to make 4 complete rotations is about 3 s.

mass of aeroplane = 5.2 g

(4)

- (iii) Student A suggests that if the radius of the canopy was increased and rotated at the same angular velocity as before, the wires supporting the aeroplanes could be vertical.

Student B suggests that the wires would be at an angle of greater than 19° to the vertical.

Explain whether either of the students is correct.

(5)

(Total for Question 16 = 14 marks)



17 Cloud chambers are used to observe the paths of particles.

The photograph shows a pair of tracks made by alpha particles emitted when an atom of radon decays in a cloud chamber.

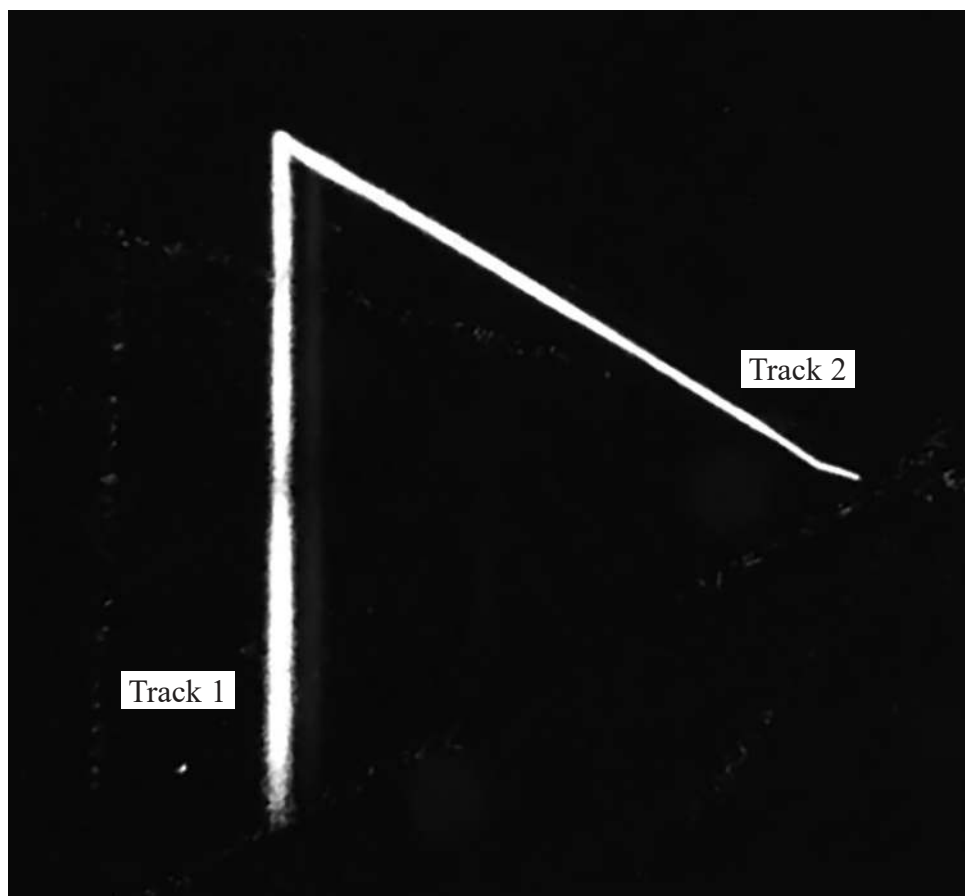

- (a) The radon atoms do not leave tracks.

State a reason for this.

(1)

- (b) Radon decays by emitting an alpha particle, producing a polonium nucleus. The polonium then decays almost immediately by emitting another alpha particle, producing a lead nucleus.

- (i) Complete the nuclear equation for this sequence of decays.

(2)

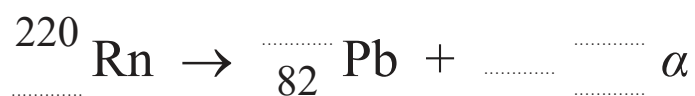

- (ii) The radon atom was stationary before the first alpha emission. The angle between the two alpha tracks is 60° .

Sketch a vector diagram to show the momentum of the two alpha particles and the lead ion.

(2)

- (iii) Determine the magnitude of the velocity of the lead ion.

velocity of alpha particle emitted by radon = $1.74 \times 10^7 \text{ m s}^{-1}$

velocity of alpha particle emitted by polonium = $1.81 \times 10^7 \text{ m s}^{-1}$

mass of lead ion = $3.52 \times 10^{-25} \text{ kg}$

(6)

.....

.....

.....

.....

.....

.....

.....

.....

.....

.....

.....

.....

.....

.....

.....

.....

.....

.....

.....

.....

.....

.....

Magnitude of velocity =

DO NOT WRITE IN THIS AREA



(c) The photograph shows another pair of tracks following radon decay.



Deduce which track is for the first alpha particle emitted.

(3)

.....

.....

.....

.....

.....

.....

(Total for Question 17 = 14 marks)



- 18 The photograph shows a hospital radiotherapy machine that contains a linear accelerator (linac). The linac accelerates electrons to very high speeds for use in treating cancer.



(© Alexander Tihonov/Pearson Asset Library)

- (a) The electrons used in the linac are produced by the filament in an electron gun, as shown in the diagram.

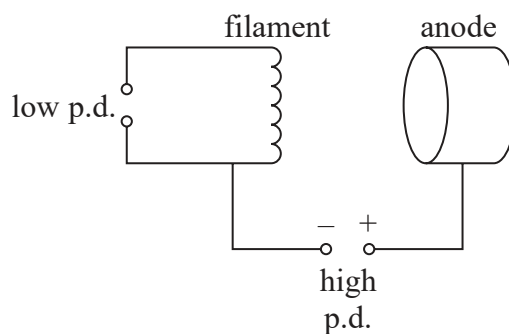

Name and describe the process in which electrons are produced by the filament.

(2)

.....

.....

.....

.....



(b) The diagram shows part of a simplified linac.

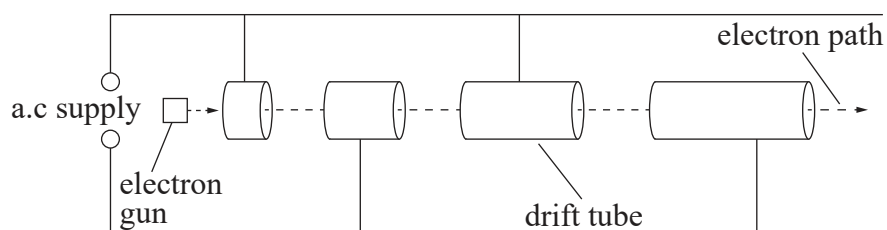

An electron enters the linac from the electron gun with a speed of $2.5 \times 10^6 \text{ m s}^{-1}$. The electron passes through 60 drift tubes before emerging from the other end.

(i) Calculate the energy of the electron as it emerges.

potential difference between adjacent drift tubes = 80 kV

(3)

Energy of the electron =

(ii) For very high energy electrons, successive drift tubes have the same length.

Explain why.

(2)



(c) Linacs used for radiotherapy operate by means of a standing wave formed within the linac.

Explain how standing waves are produced.

(3)

.....

.....

.....

.....

.....

.....

.....

.....

.....

.....

.....

DO NOT WRITE IN THIS AREA

DO NOT WRITE IN THIS AREA

DO NOT WRITE IN THIS AREA



- (d) Electrons emerging from a standing wave linac must be directed towards the patient. Magnets are used to rotate the path of the electron beam through 270° .

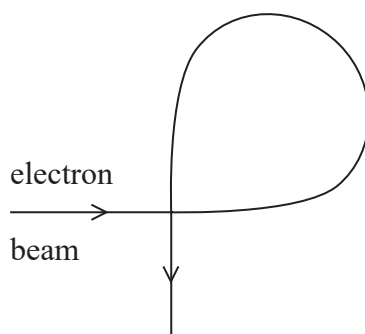

Determine the magnetic flux density required to rotate the beam through 270° .

energy of electrons = 2.5 keV

radius of curvature of path = 61 mm

(4)

.....

.....

.....

.....

.....

.....

Magnetic flux density =

(Total for Question 18 = 14 marks)

TOTAL FOR SECTION B = 80 MARKS

TOTAL FOR PAPER = 90 MARKS



List of data, formulae and relationships

Acceleration of free fall	$g = 9.81 \text{ m s}^{-2}$	(close to Earth's surface)
Boltzmann constant	$k = 1.38 \times 10^{-23} \text{ J K}^{-1}$	
Coulomb's law constant	$k = 1/4\pi\epsilon_0$ $= 8.99 \times 10^9 \text{ N m}^2 \text{ C}^{-2}$	
Electron charge	$e = -1.60 \times 10^{-19} \text{ C}$	
Electron mass	$m_e = 9.11 \times 10^{-31} \text{ kg}$	
Electronvolt	$1 \text{ eV} = 1.60 \times 10^{-19} \text{ J}$	
Gravitational constant	$G = 6.67 \times 10^{-11} \text{ N m}^2 \text{ kg}^{-2}$	
Gravitational field strength	$g = 9.81 \text{ N kg}^{-1}$	(close to Earth's surface)
Permittivity of free space	$\epsilon_0 = 8.85 \times 10^{-12} \text{ F m}^{-1}$	
Planck constant	$h = 6.63 \times 10^{-34} \text{ J s}$	
Proton mass	$m_p = 1.67 \times 10^{-27} \text{ kg}$	
Speed of light in a vacuum	$c = 3.00 \times 10^8 \text{ m s}^{-1}$	
Stefan-Boltzmann constant	$\sigma = 5.67 \times 10^{-8} \text{ W m}^{-2} \text{ K}^{-4}$	
Unified atomic mass unit	$u = 1.66 \times 10^{-27} \text{ kg}$	

Unit 1

Mechanics

Kinematic equations of motion

$$s = \frac{(u + v)t}{2}$$

$$v = u + at$$

$$s = ut + \frac{1}{2}at^2$$

$$v^2 = u^2 + 2as$$

Forces

$$\Sigma F = ma$$

$$g = \frac{F}{m}$$

$$W = mg$$

Momentum

$$p = mv$$

Moment of force

$$\text{moment} = Fx$$

Work and energy

$$\Delta W = F\Delta s$$

$$E_k = \frac{1}{2}mv^2$$

$$\Delta E_{\text{grav}} = mg\Delta h$$

Power

$$P = \frac{E}{t}$$

$$P = \frac{W}{t}$$

Efficiency

$$\text{efficiency} = \frac{\text{useful energy output}}{\text{total energy input}}$$

$$\text{efficiency} = \frac{\text{useful power output}}{\text{total power input}}$$



Materials

Density

$$\rho = \frac{m}{V}$$

Stokes' law

$$F = 6\pi\eta rv$$

Hooke's law

$$F = k\Delta x$$

Elastic strain energy

$$\Delta E_{\text{el}} = \frac{1}{2}F\Delta x$$

Young modulus

$$E = \frac{\sigma}{\varepsilon} \text{ where}$$

$$\text{Stress } \sigma = \frac{F}{A}$$

$$\text{Strain } \varepsilon = \frac{\Delta x}{x}$$

DO NOT WRITE IN THIS AREA

DO NOT WRITE IN THIS AREA

DO NOT WRITE IN THIS AREA



Unit 2

Waves

Wave speed	$v = f\lambda$
Speed of a transverse wave on a string	$v = \sqrt{\frac{T}{\mu}}$
Intensity of radiation	$I = \frac{P}{A}$
Refractive index	$n_1 \sin \theta_1 = n_2 \sin \theta_2$ $n = \frac{c}{v}$
Critical angle	$\sin C = \frac{1}{n}$
Diffraction grating	$n\lambda = d \sin \theta$

Electricity

Potential difference	$V = \frac{W}{Q}$
Resistance	$R = \frac{V}{I}$
Electrical power, energy	$P = VI$ $P = I^2R$ $P = \frac{v^2}{R}$ $W = VIt$
Resistivity	$R = \frac{\rho l}{A}$
Current	$I = \frac{\Delta Q}{\Delta t}$ $I = nqvA$
Resistors in series	$R = R_1 + R_2 + R_3$
Resistors in parallel	$\frac{1}{R} = \frac{1}{R_1} + \frac{1}{R_2} + \frac{1}{R_3}$

Particle nature of light

Photon model	$E = hf$
Einstein's photoelectric equation	$hf = \phi + \frac{1}{2}mv_{\max}^2$
de Broglie wavelength	$\lambda = \frac{h}{p}$



Unit 4*Mechanics*

Impulse

$$F\Delta t = \Delta p$$

Kinetic Energy of a non-relativistic particle

$$E_k = \frac{p^2}{2m}$$

motion in a circle

$$v = \omega r$$

$$T = \frac{2\pi}{\omega}$$

$$a = \frac{v^2}{r}$$

Centripetal force

$$F = ma = \frac{mv^2}{r}$$

$$F = m\omega^2 r$$

Electric and magnetic fields

Electric Field

$$E = \frac{F}{Q}$$

Coulomb's Law

$$F = \frac{Q_1 Q_2}{4\pi\epsilon_0 r^2}$$

$$E = \frac{Q}{4\pi\epsilon_0 r^2}$$

$$E = \frac{V}{d}$$

Electrical Potential

$$V = \frac{Q}{4\pi\epsilon_0 r}$$

Capacitance

$$C = \frac{Q}{d}$$

Energy Stored in capacitor

$$W = \frac{1}{2} QV$$

$$W = \frac{1}{2} CV^2$$

$$W = \frac{1}{2} \frac{Q^2}{C}$$

Capacitor discharge

$$Q = Q_0 e^{-t/RC}$$



Resistor capacitor discharge

$$I = I_0 e^{-t/RC}$$

$$V = V_0 e^{-t/RC}$$

$$\ln Q = \ln Q_0 - \frac{t}{RC}$$

$$\ln I = \ln I_0 - \frac{t}{RC}$$

$$\ln V = \ln V_0 - \frac{t}{RC}$$

In a magnetic field

$$F = Bqv \sin\theta$$

$$F = BIl \sin\theta$$

Faraday and Lenz's law

$$\varepsilon = \frac{-d(N\phi)}{dt}$$

Nuclear and particle physics

In a magnetic field

$$r = \frac{p}{BQ}$$

Mass-energy

$$\Delta E = c^2 \Delta m$$



DO NOT WRITE IN THIS AREA

DO NOT WRITE IN THIS AREA

DO NOT WRITE IN THIS AREA

BLANK PAGE

